

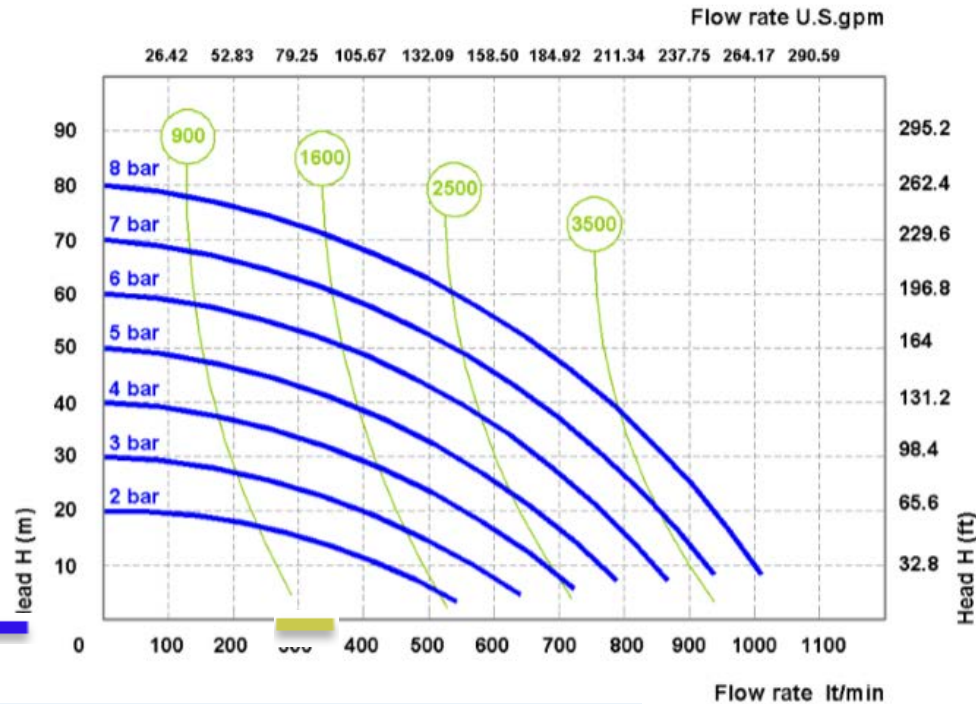

Conexiones: Tri Clamp 3''  
 Caudal máximo: 1050 l/min  
 Conector de aire: 3/4'' BSP  
 Presión máxima: 8 bar  
 Max aspiración neg en seco: 6 metros  
 Max aspiración neg con fluido: 9,8 metros  
 Pasaje de sólidos: 10 mm  
 Ruido: 78 dB  
 Cilindrada por ciclo: 2825 cc  
 Viscosidad máxima: 55.000 cps  
 ATEX zona 1: EX II 2/2 GD c IIBB T135°C  
 ATEX zona 2: EX II 3/3 GD c IIBB T135°C



Presión de alimentación de aire

Consumo de aire NI/mir

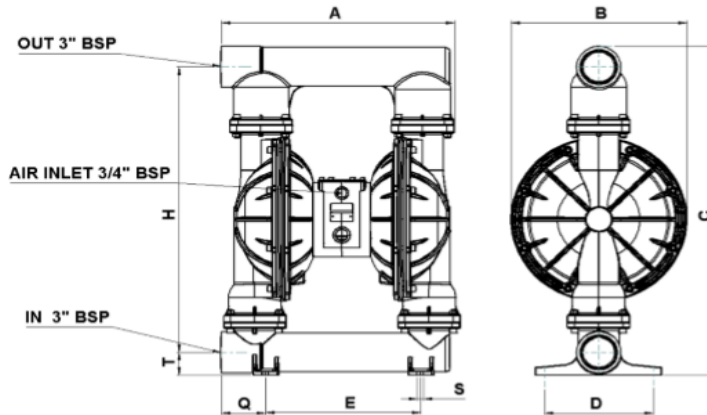

PHOENIX PF1000	A	B	C	D	E	H	Q	S	T	Weight Kg	Max Temperature
AISI 316	570	417	838	258	368	727	105	15	58	120	95°C